

## HIGH PERFORMANCE QUAD OPERATIONAL AMPLIFIERS

- SINGLE OR SPLIT SUPPLY OPERATION
- VERY LOW POWER CONSUMPTION
- SHORT CIRCUIT PROTECTION
- LOW DISTORTION, LOW NOISE
- HIGH GAIN-BANDWIDTH PRODUCT
- HIGH CHANNEL SEPARATION

### DESCRIPTION

The LS404 is a high performance quad operational amplifier with frequency and phase compensation built into the chip. The internal phase compensation allows stable operation as voltage follower in spite of its high gain-bandwidth product. The circuit presents very stable electrical characteristics over the entire supply voltage range, and it is particularly intended for professional and telecom applications (active filters, etc.).

The patented input stage circuit allows small input signal swings below the negative supply voltage and prevents phase inversion when the input is over driven.

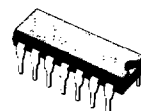

**DIP14**  
(Plastic 0.25)



**SO-14J**

### CONNECTION DIAGRAM AND ORDERING NUMBERS (top view)

Type	DIP 14	SO-14
LS404	—	LS404D1
LS404C	LS404CB	LS404CD1
LS 8404	—	LS 8404M
LS8404C	—	LS 89404CM

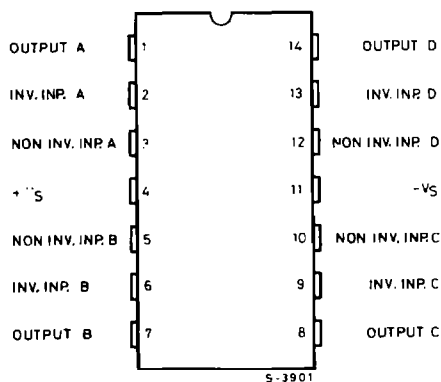

SCHEMATIC DIAGRAM (one section)

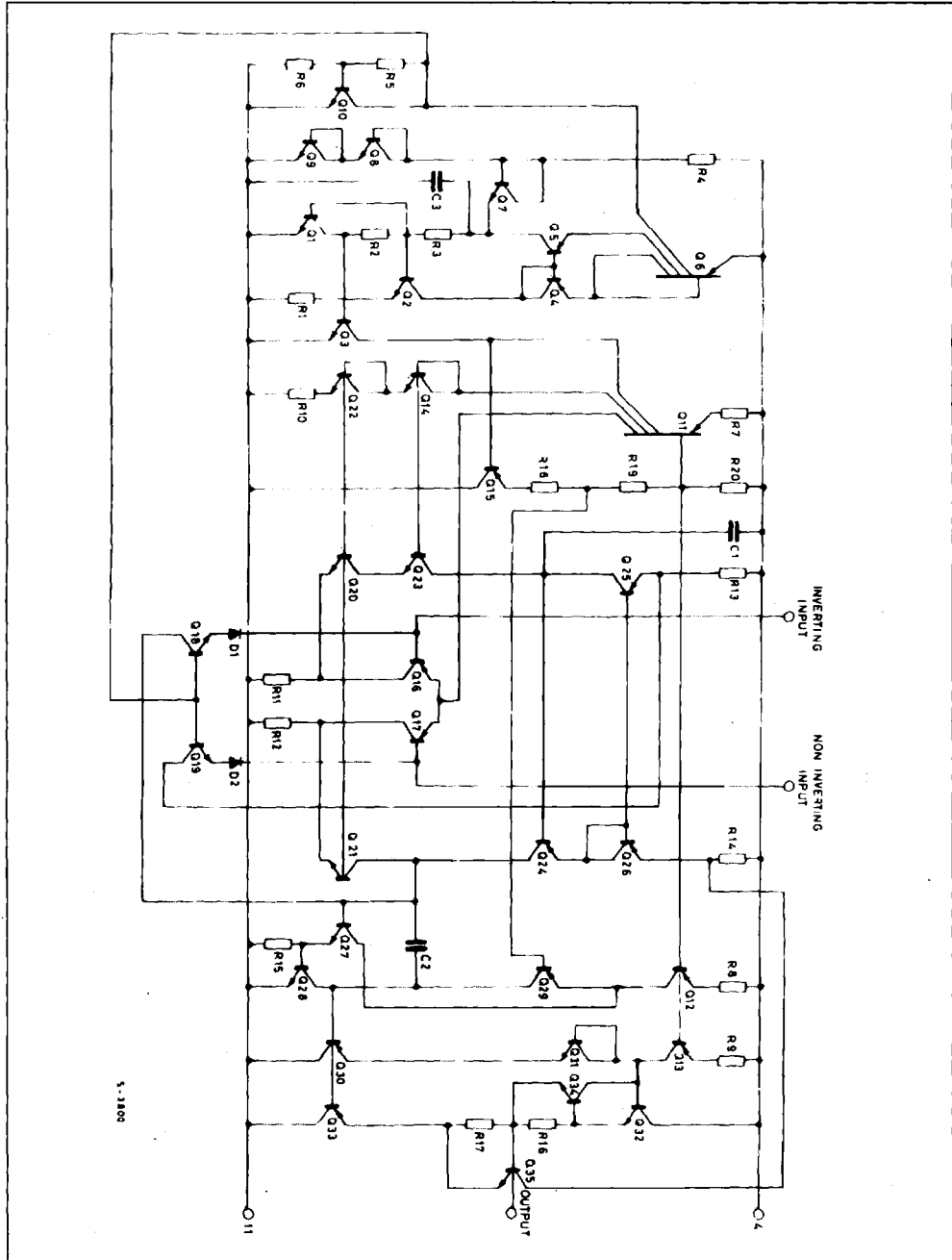

## ABSOLUTE MAXIMUM RATINGS

Symbol	Parameter	Value	Unit
$V_s$	Supply Voltage	$\pm 18$	V
$V_i$	Input Voltage (positive) (negative)	$+ V_s$ $- V_s - 0.5$	V
$V_d$	Differential Input Voltage	$\pm (V_s - 1)$	
$T_{op}$	Operating Temperature	<b>LS404</b> <b>LS404C</b> $- 25$ to $+ 85$ $0$ to $+ 70$	$^{\circ}\text{C}$ $^{\circ}\text{C}$
$P_{tot}$	Power Dissipation ( $T_{amb} = 70^{\circ}\text{C}$ )	400	mW
$T_{stg}$	Storage Temperature	$- 55$ to $+ 150$	$^{\circ}\text{C}$

## THERMAL DATA

		DIP 14	SO-14 J
$R_{thj-amb}$	Thermal Resistance Junction-ambient	Max	200 $^{\circ}\text{C}/\text{W}$

(\* Measured with the device mounted on a ceramic substrate (25 x 16 x 0.6 mm).

ELECTRICAL CHARACTERISTICS ( $V_s = \pm 12$  V,  $T_{amb} = 25$   $^{\circ}\text{C}$ , unless otherwise specified)

Symbol	Parameter	Test Conditions	LS404			LS404C			Unit
			Min.	Typ.	Max.	Min.	Typ.	Max.	
$I_s$	Supply Current			1.3	2		1.5	3	mA
$I_b$	Input Bias Current			50	200		100	300	nA
$R_i$	Input Resistance	$f = 1$ KHz		0.7	2.5		0.5	5	$\text{M}\Omega$
$V_{os}$	Input Offset Voltage	$R_g = 10$ K $\Omega$		1			1		mV
$\frac{\Delta V_{os}}{\Delta T}$	Input Offset Voltage Drift	$R_g = 10$ K $\Omega$ $T_{min} < T_{op} < T_{max}$		5			5		$\mu\text{V}/^{\circ}\text{C}$
$I_{os}$	Input Offset Current			10	40		20	80	nA
$\frac{\Delta I_{os}}{\Delta T}$	Input Offset Current Drift	$T_{min} < T_{op} < T_{max}$		0.08			0.1		$\frac{\text{nA}}{^{\circ}\text{C}}$
$I_{sc}$	Output Short Circuit Current			23			23		mA
$G_v$	Large Signal Open Loop Voltage Gain	$R_L = 2$ K $\Omega$ $V_s = \pm 12$ V $V_s = \pm 4$ V	90	100 95		86	100 95		dB
B	Gain-bandwidth Product	$f = 20$ KHz	1.8	3		1.5	2.5		MHz
$e_N$	Total Input Noise Voltage	$f = 1$ KHz $R_g = 50$ $\Omega$ $R_g = 1$ K $\Omega$ $R_g = 10$ K $\Omega$		8 10 18	15		10 12 20		$\frac{\text{nV}}{\sqrt{\text{Hz}}}$
d	Distortion	Unity Gain $R_L = 2$ K $\Omega$ $V_o = 2$ V <sub>PP</sub> $f = 1$ KHz $f = 20$ KHz		0.01 0.03	0.04		0.01 0.03		%
$V_o$	DC Output Voltage Swing	$R_L = 2$ K $\Omega$ $V_s = \pm 12$ V $V_s = \pm 4$ V	$\pm 10$	$\pm 3$		$\pm 10$	$\pm 3$		V

**ELECTRICAL CHARACTERISTICS** (continued)

Symbol	Parameter	Test Conditions	LS404			LS404C			Unit
			Min.	Typ.	Max.	Min.	Typ.	Max.	
$V_o$	Large Signal Voltage Swing	$f = 10 \text{ KHz}$ $R_L = 10 \text{ K}\Omega$ $R_L = 1 \text{ K}\Omega$		22 20			22 20		$V_{pp}$
SR	Slew Rate	Unity Gain $R_L = 2 \text{ K}\Omega$	0.8	1.5			1		$V/\mu\text{s}$
CMR	Common Mode Rejection	$V_i = 10 \text{ V}$	90	94		80	90		dB
SVR	Supply Voltage Rejection	$V_i = 1 \text{ V}$ $f = 100 \text{ Hz}$	90	94		86	90		dB
CS	Channel Separation	$f = 1 \text{ KHz}$	100	120			120		dB

**Figure 1:** Supply Current vs. Supply Voltage.

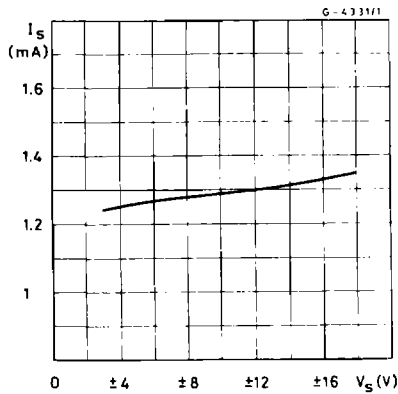

**Figure 2:** Supply Current vs. Ambient Temperature.

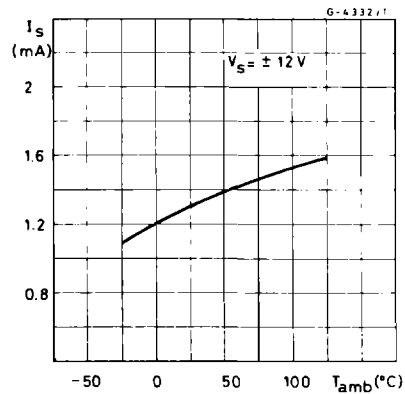

**Figure 3:** Output Short Circuit Current vs. Ambient Temperature.

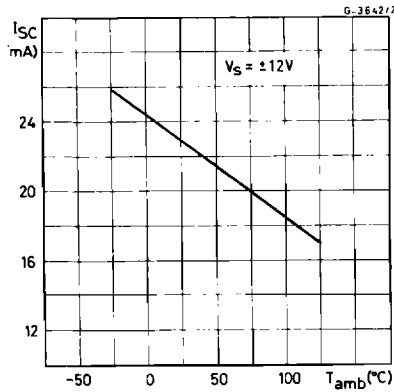

**Figure 4:** Open Loop Frequency and Phase Response.

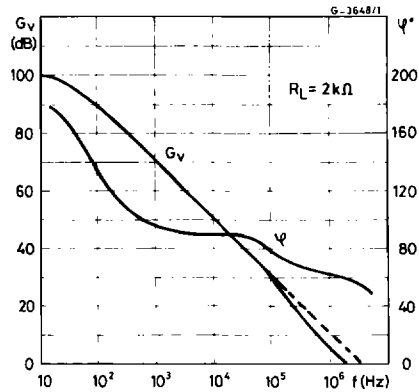

**Figure 5:** Open Loop Gain vs. Ambient Temperature.

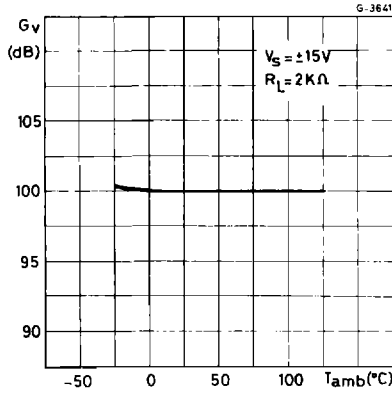

**Figure 7:** Large Signal Frequency Response.

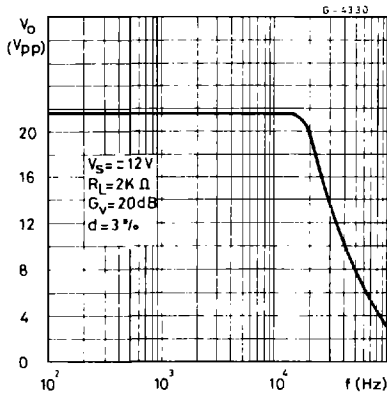

**Figure 9:** Total Input Noise vs. Frequency.

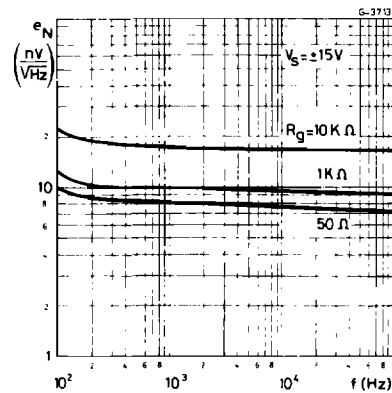

**Figure 6:** Supply Voltage Rejection vs. Frequency.

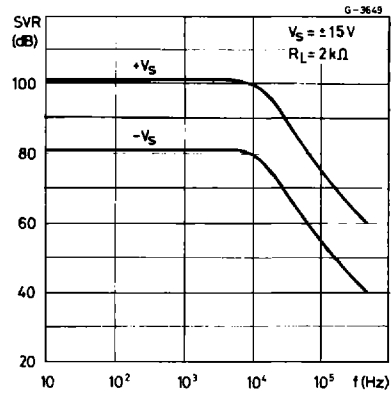

**Figure 8:** Output Voltage Swing vs. Load Resistance.

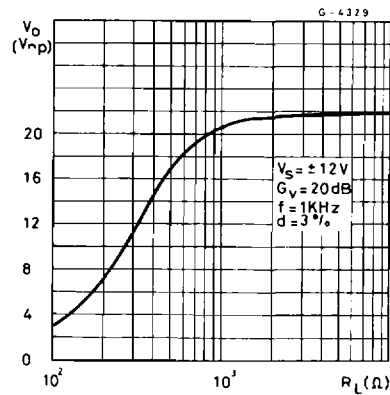

**APPLICATION INFORMATION**

**Active low-pass filter :**

**BUTTERWORTH**

The Butterworth is a "maximally flat" amplitude response filter. Butterworth filters are used for filtering signals in data acquisition systems to prevent aliasing errors in sampled-data applications and for general purpose low-pass filtering.

The cutoff frequency,  $f_c$ , is the frequency at which the amplitude response is down 3 dB. The attenuation rate beyond the cutoff frequency is - n6 dB per octave of frequency where n is the order (number of poles) of the filter.

Other characteristics :

- Flattest possible amplitude response.
- Excellent gain accuracy at low frequency end of passband.

**Figure 10 : Amplitude Response.**

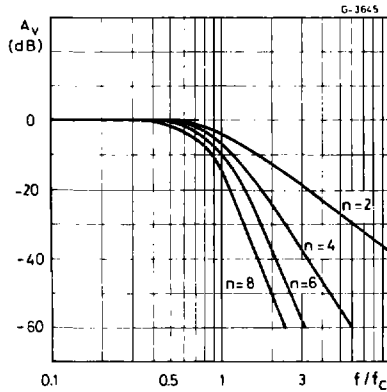

**BESSEL**

The Bessel is a type of "linear phase" filter. Because of their linear phase characteristics, these filters approximate a constant time delay over a limited frequency range. Bessel filters pass transient waveforms with a minimum of distortion. They are also used to provide time delays for low pass filtering of modulated waveforms and as a "running average" type filter.

The maximum phase shift is  $-\frac{n\pi}{2}$  radians where n is the order (number of poles) of the filter. The cut-off frequency,  $f_c$ , is defined as the frequency at which the phase shift is one half to this value. For accurate delay, the cutoff frequency should be twice the maxi-

imum signal frequency. The following table can be used to obtain the - 3 dB frequency of the filter.

	2 pole	4 Pole	6 Pole	8 Pole
- 3dB Frequency	0.77 $f_c$	0.67 $f_c$	0.57 $f_c$	0.50 $f_c$

Other characteristics :

- Selectivity not as great as Chebyshev or Butterworth.
- Very small overshoot response to step inputs.
- Fast rise time.

**Figure 11 : Amplitude Response.**

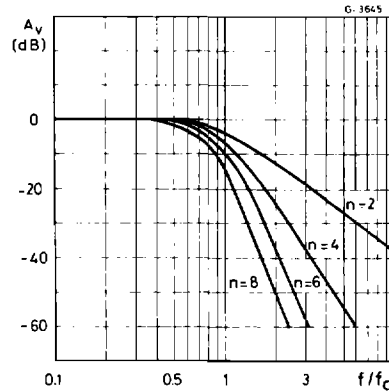

**CHEBYSCHEV**

Chebyshev filters have greater selectivity than either Bessel or Butterworth at the expense of ripple in the passband.

**Figure 12 : Amplitude Response ( ± 1 dB ripple).**

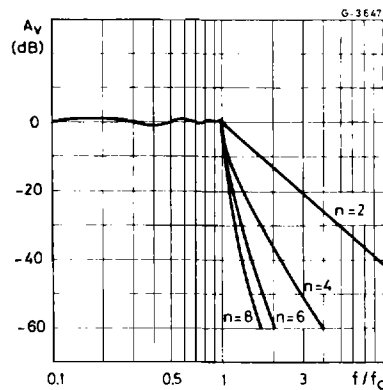

**APPLICATION INFORMATION** (continued)

Chebyshev filters are normally designed with peak-to-peak ripple values from 0.2 dB to 2 dB.

Increased ripple in the passband allows increased attenuation above the cutoff frequency.

The cutoff frequency is defined as the frequency at which the amplitude response passes through the

specified maximum ripple band and enters the stop band.

Other characteristics :

- Greater selectivity.
- Very nonlinear phase response.
- High overshoot response to step inputs.

The table below shows the typical overshoot and setting time response of the low pass filter to a step input.

	Number of Poles	Peak Overshoot	Settling Time (% of final value)		
		% Overshoot	± 1%	± 0.1%	± 0.01%
Butterworth	2	4	1.1 f <sub>c</sub> sec	1.7 f <sub>c</sub> sec	1.9 f <sub>c</sub> sec.
	4	11	1.7 f <sub>c</sub>	2.8 f <sub>c</sub>	3.8 f <sub>c</sub>
	6	14	2.4 f <sub>c</sub>	3.9 f <sub>c</sub>	5.0 f <sub>c</sub>
	8	16	3.1 f <sub>c</sub>	5.1 f <sub>c</sub>	7.1 f <sub>c</sub>
Bessel	2	0.4	0.8 f <sub>c</sub>	1.4 f <sub>c</sub>	1.7 f <sub>c</sub>
	4	0.8	1.0 f <sub>c</sub>	1.8 f <sub>c</sub>	2.4 f <sub>c</sub>
	6	0.6	1.3 f <sub>c</sub>	2.1 f <sub>c</sub>	2.7 f <sub>c</sub>
	8	0.3	1.6 f <sub>c</sub>	2.3 f <sub>c</sub>	3.2 f <sub>c</sub>
Chebyshev (ripple ± 0.25dB)	2	11	1.1 f <sub>c</sub>	1.6 f <sub>c</sub>	-
	4	18	3.0 f <sub>c</sub>	5.4 f <sub>c</sub>	-
	6	21	5.9 f <sub>c</sub>	10.4 f <sub>c</sub>	-
	8	23	8.4 f <sub>c</sub>	16.4 f <sub>c</sub>	-
Chebyshev (ripple ± 1dB)	2	21	1.6 f <sub>c</sub>	2.7 f <sub>c</sub>	-
	4	28	4.8 f <sub>c</sub>	8.4 f <sub>c</sub>	-
	6	32	8.2 f <sub>c</sub>	16.3 f <sub>c</sub>	-
	8	34	11.6 f <sub>c</sub>	24.8 f <sub>c</sub>	-

Design of 2<sup>nd</sup> order active low pass filter (Sallen and Key configuration unity gain op-amp)

**Figure 13** : Filter Configuration.

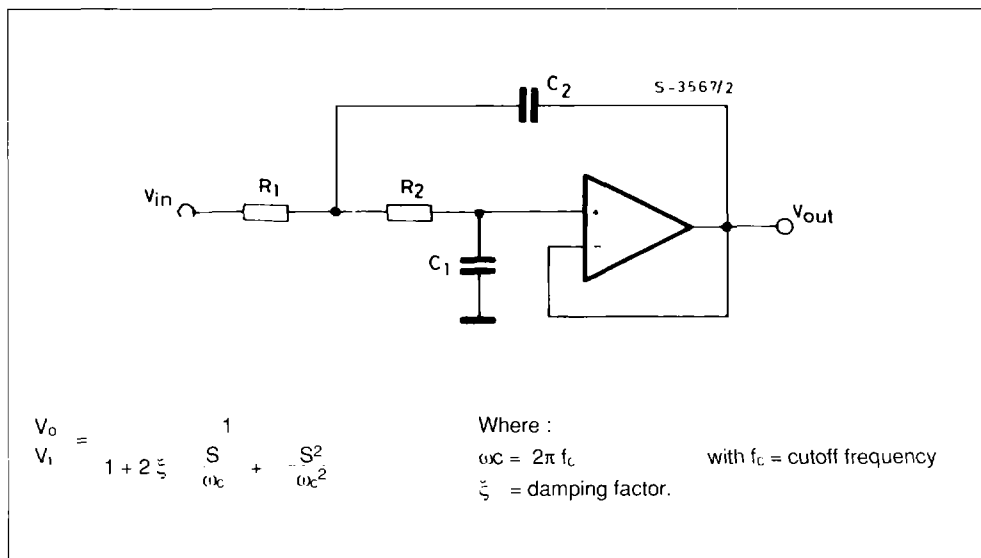

**APPLICATION INFORMATION** (continued)

Three parameters are needed to characterize the frequency and phase response of a 2<sup>nd</sup> order active filter : the gain ( $G_v$ ), the damping factor ( $\xi$ ) or the Q-factor ( $Q = (2\xi)^{-1}$ ), and the cutoff frequency ( $f_c$ ).

ries of 2<sup>nd</sup> order sections. A simple RC section is introduced when an odd filter is required.

The choice of ' $\xi$ ' (or Q-factor) determines the filter response (see table).

The higher order responses are obtained with a se-

**Table 1.**

Filter Response	$\xi$	Q	Cutoff Frequency $f_c$
Bessel	$\frac{\sqrt{3}}{2}$	$\frac{1}{\sqrt{3}}$	Frequency at which Phase Shift is $-90^\circ$ C
Butterworth	$\frac{\sqrt{2}}{2}$	$\frac{1}{\sqrt{2}}$	Frequency at which $G_v = -3$ dB
Chebyshev	$< \frac{\sqrt{2}}{2}$	$> \frac{1}{\sqrt{2}}$	Frequency at which the amplitude response passes through specified max. ripple band and enters the stop band.

**Figure 14 :** Filter Response vs. Damping Factor.

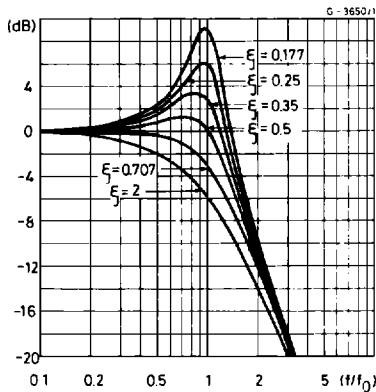

Fixed  $R = R_1 = R_2$ , we have (see fig. 13)

$$C_1 = \frac{1}{R} \frac{\xi}{\omega_c}$$

$$C_2 = \frac{1}{R} \frac{1}{\xi \omega_c}$$

The diagram of fig.14 shows the amplitude response for different values of damping factor  $\xi$  in 2<sup>nd</sup> order filters.

**EXAMPLE**

**Figure 15 :** 5<sup>th</sup> Order Low Pass Filter (Butterworth) with Unity Gain Configuration.

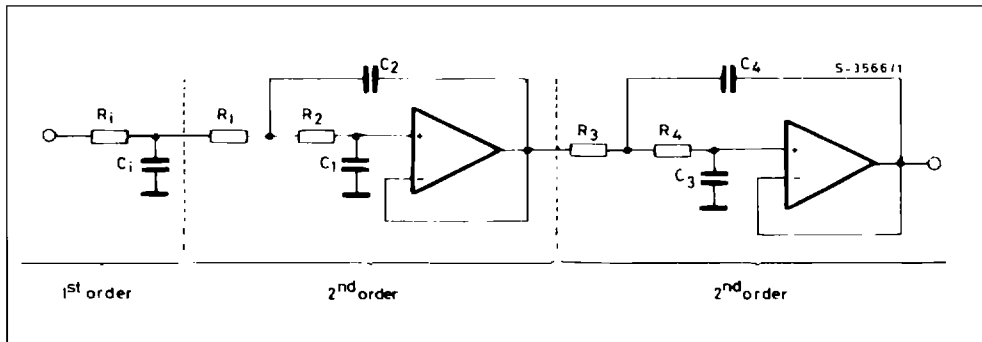



**APPLICATION INFORMATION** (continued)

In the circuit of fig. 15, for  $f_c = 3.4$  KHz and  $R_i = R_1 = R_2 = R_3 = R_4 = 10$  K $\Omega$ , we obtain :

$$C_1 = 1.354 \cdot \frac{1}{R} \cdot \frac{1}{2\pi f_c} = 6.33 \text{ nF}$$

$$C_1 = 0.421 \cdot \frac{1}{R} \cdot \frac{1}{2\pi f_c} = 1.97 \text{ nF}$$

$$C_2 = 1.753 \cdot \frac{1}{R} \cdot \frac{1}{2\pi f_c} = 8.20 \text{ nF}$$

$$C_3 = 0.309 \cdot \frac{1}{R} \cdot \frac{1}{2\pi f_c} = 1.45 \text{ nF}$$

$$C_4 = 3.325 \cdot \frac{1}{R} \cdot \frac{1}{2\pi f_c} = 15.14 \text{ nF}$$

The attenuation of the filter is 30 dB at 6.8 KHz and better than 60 dB at 15 KHz.

The same method, referring to Tab. II and fig. 16, is used to design high-pass filter. In this case the damping factor is found by taking the reciprocal of the numbers in Tab. II. For  $f_c = 5$  KHz and  $C_1 = C_1 = C_2 = C_3 = C_4 = 1$  nF we obtain :

$$R_1 = \frac{1}{1.354} \cdot \frac{1}{C} \cdot \frac{1}{2\pi f_c} = 23.5 \text{ K}\Omega$$

$$R_1 = \frac{1}{0.421} \cdot \frac{1}{C} \cdot \frac{1}{2\pi f_c} = 75.6 \text{ K}\Omega$$

$$R_2 = \frac{1}{1.753} \cdot \frac{1}{C} \cdot \frac{1}{2\pi f_c} = 18.2 \text{ K}\Omega$$

$$R_3 = \frac{1}{0.309} \cdot \frac{1}{C} \cdot \frac{1}{2\pi f_c} = 103 \text{ K}\Omega$$

$$R_4 = \frac{1}{3.325} \cdot \frac{1}{C} \cdot \frac{1}{2\pi f_c} = 9.6 \text{ K}\Omega$$

**Table II** : Damping Factor for Low-pass Butterworth Filters.

Order	C <sub>1</sub>	C <sub>2</sub>	C <sub>3</sub>	C <sub>4</sub>	C <sub>5</sub>	C <sub>6</sub>	C <sub>7</sub>	C <sub>8</sub>
2		0.707	1.41					
3	1.392	0.202	3.54					
4		0.92	1.08	0.38	2.61			
5	1.354	0.421	1.75	0.309	3.235			
6		0.966	1.035	0.707	1.414	0.259	3.86	
7	1.336	0.488	1.53	0.623	1.604	0.222	4.49	
8		0.98	1.02	0.83	1.20	0.556	1.80	0.195

**Figure 16** : 5<sup>th</sup> Order High-pass Filter (Butterworth) with Unity Gain Configuration.

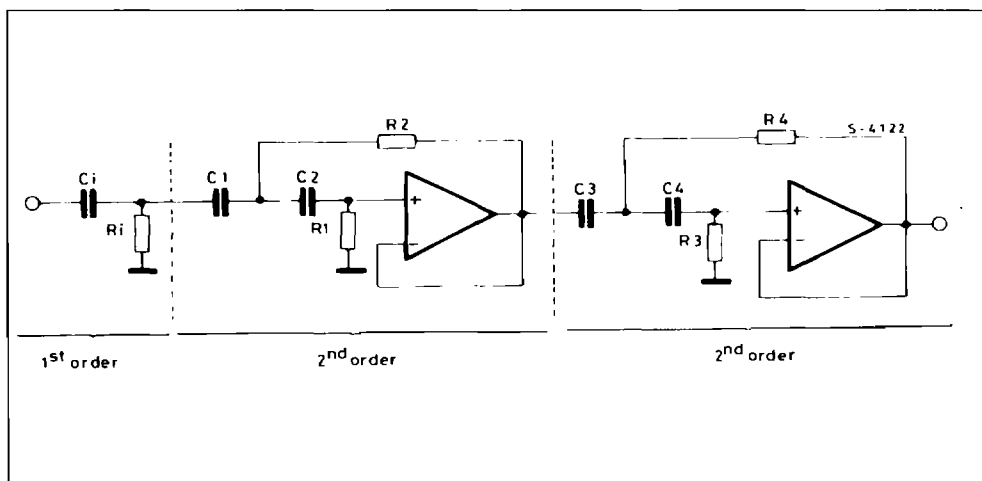

APPLICATION INFORMATION (continued)

Figure 17 : Multiple Feedback 8-pole Bandpass Filter.

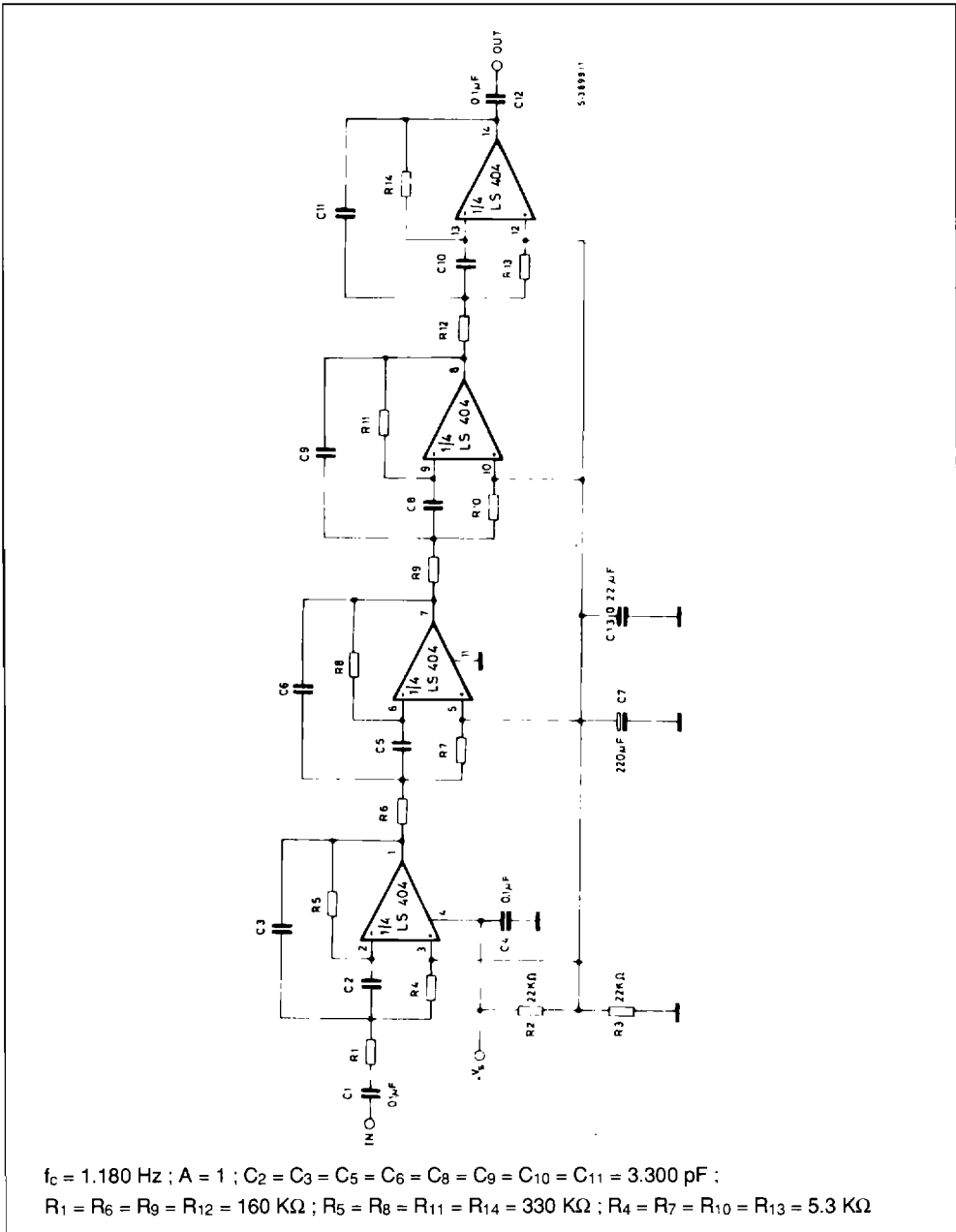

**Figure 18** : Frequency Response of Band-pass Filter.

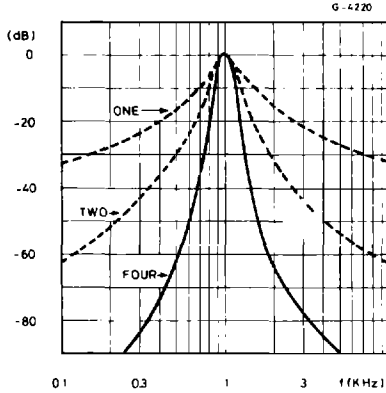

**Figure 19** : Bandwidth of Band-pass Filter.

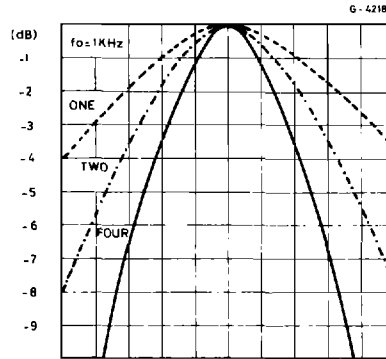

**Figure 20** : Six-pole 355 Hz Low-pass Filter (chebychev type).

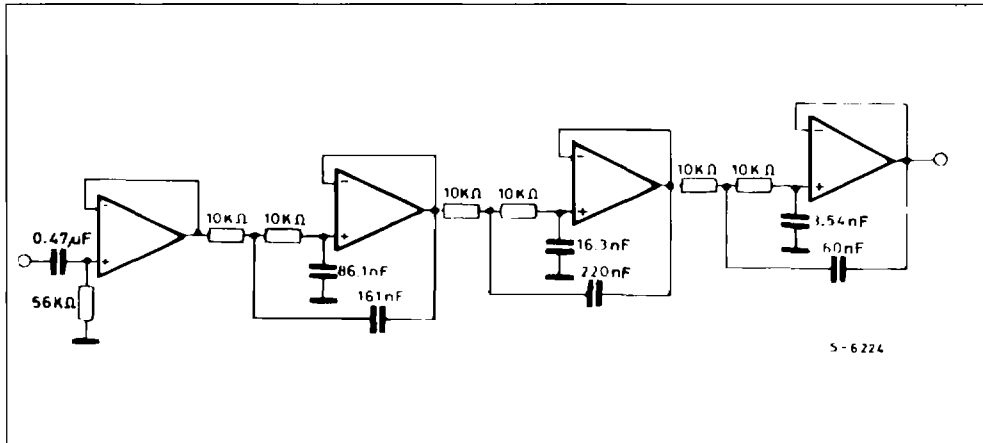

This is a 6-pole Chebyshev type with  $\pm 0.25$  dB ripple in the passband. A decoupling stage is used to avoid the influence of the input impedance on the filter's characteristics. The attenuation is about

55 dB at 710 Hz and reaches 80 dB at 1065 Hz. The in band attenuation is limited in practice to the  $\pm 0.25$  dB ripple and does not exceed 0.5 dB at 0.9 fc.

Figure 21 : Subsonic Filter ( $G_v = 0$  dB).

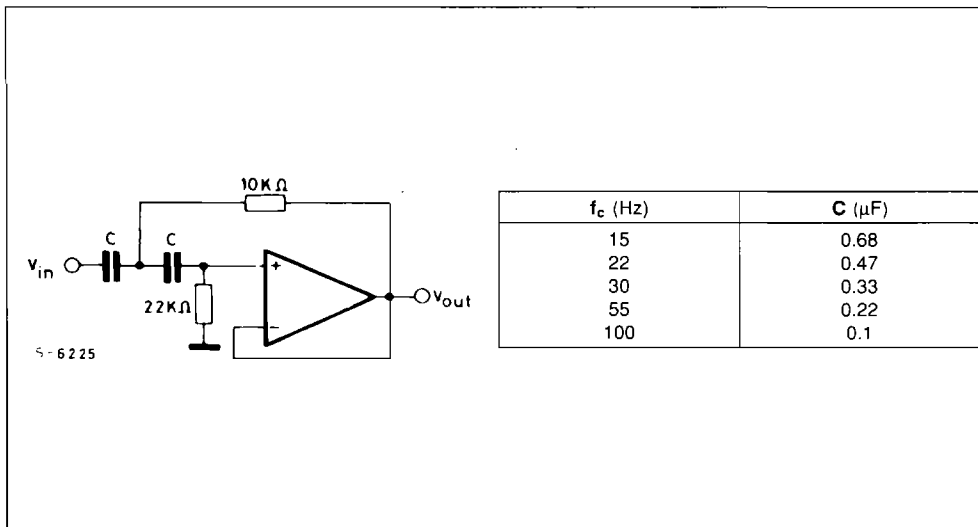

Figure 22 : High Cut Filter ( $G_v = 0$  dB).

